

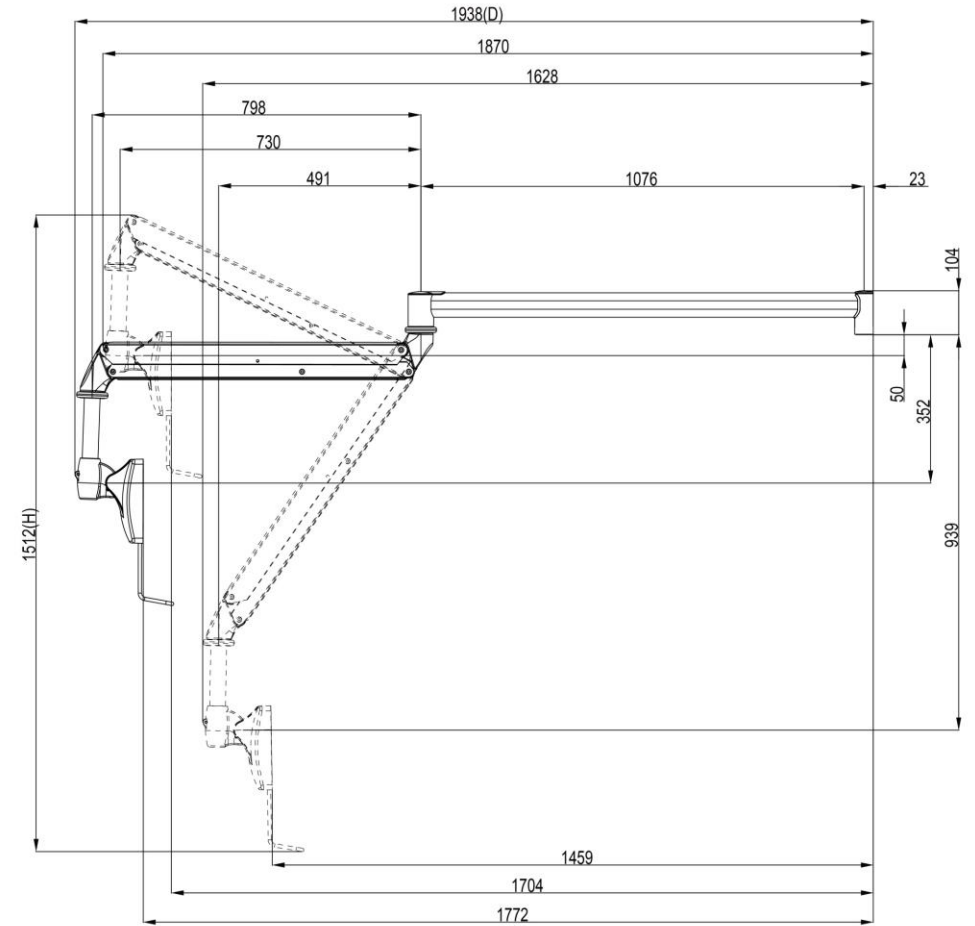

www.topskys.com

Model Name:ALB21L

完整的系统		
净重	11 Kg(24.25 lbs)	
尺寸(W*H*D)	200x1512x1968mm(7.87"x59.53"x77.48)	
螺丝型号	M4	
材质	锌铝合金/塑胶/钢	
显示系统		
铰链模块	旋转 (铰链)	+/-185°
	旋转I(VESA)	+/-5°
	倾斜 (铰链)	-60° ~ +20°
	用户扭矩调整	可用
显示屏支持	安装孔位	100x100 / 75x75mm
	显示类型	单监视器
	屏幕尺寸支持	15"~24"
	支撑重量 (范围)	6~12kg(13.23~26.46 lbs)
高度调节	旋转臂 (1)	+/-90°
	旋转臂 (2)	+/-185°
	高度调节范围 (臂)	890mm (35.04")
	张力扭矩调整	Yes
	倾斜 (臂)	-55°(down) ~ +25°(up)
提供延伸臂	2	
电缆管理	Yes	



Rotate

